

a sound relationship

Russound

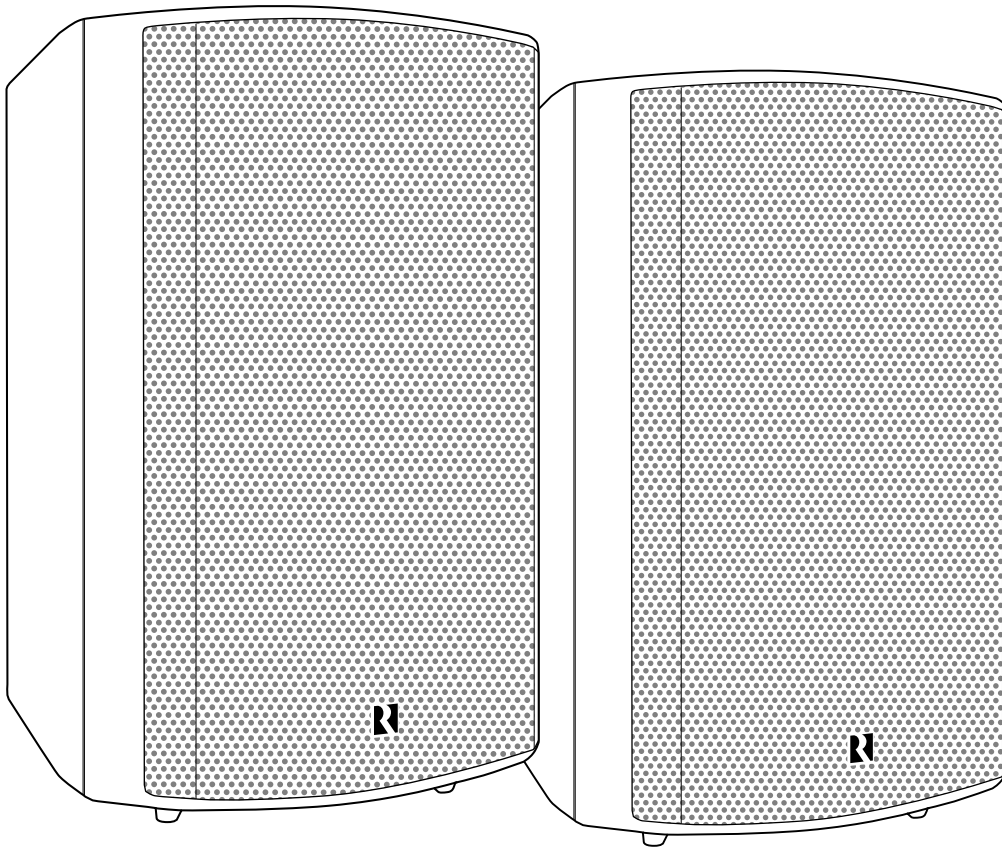

AW70V6mk2
70V Surface Mount Indoor/Outdoor Speakers
Installation Manual

Introduction

Thank you for selecting the AW70V6mk2 speakers from Russound.

The AW70V6mk2 speakers are designed to add high quality, custom-tailored sound for distributed audio systems using either 70V or 100V amplification. With an easily adjustable weatherproof tap setting switch on the rear panel, these versatile speakers even include a bypass setting to allow their use as high performance 6-ohm speakers. Their 1" titanium dome tweeters combined in a ported-cabinet design with 6.5" injection-molded polypropylene woofers, provide the audio quality that our customers have come to know and expect from Russound, while rugged enough for even the most extreme outdoor environments.

Speaker assembly

The bracket has screw slots to accommodate either wall, ceiling and pole-mounted installation options. A "C-slot" bracket design allows for one-handed installation by allowing the bracket to support the speaker's weight until it is locked into position. Custom, easy-to-turn, weather-resistant knobs provide a versatile and cosmetic finish for the brackets' attachment points.

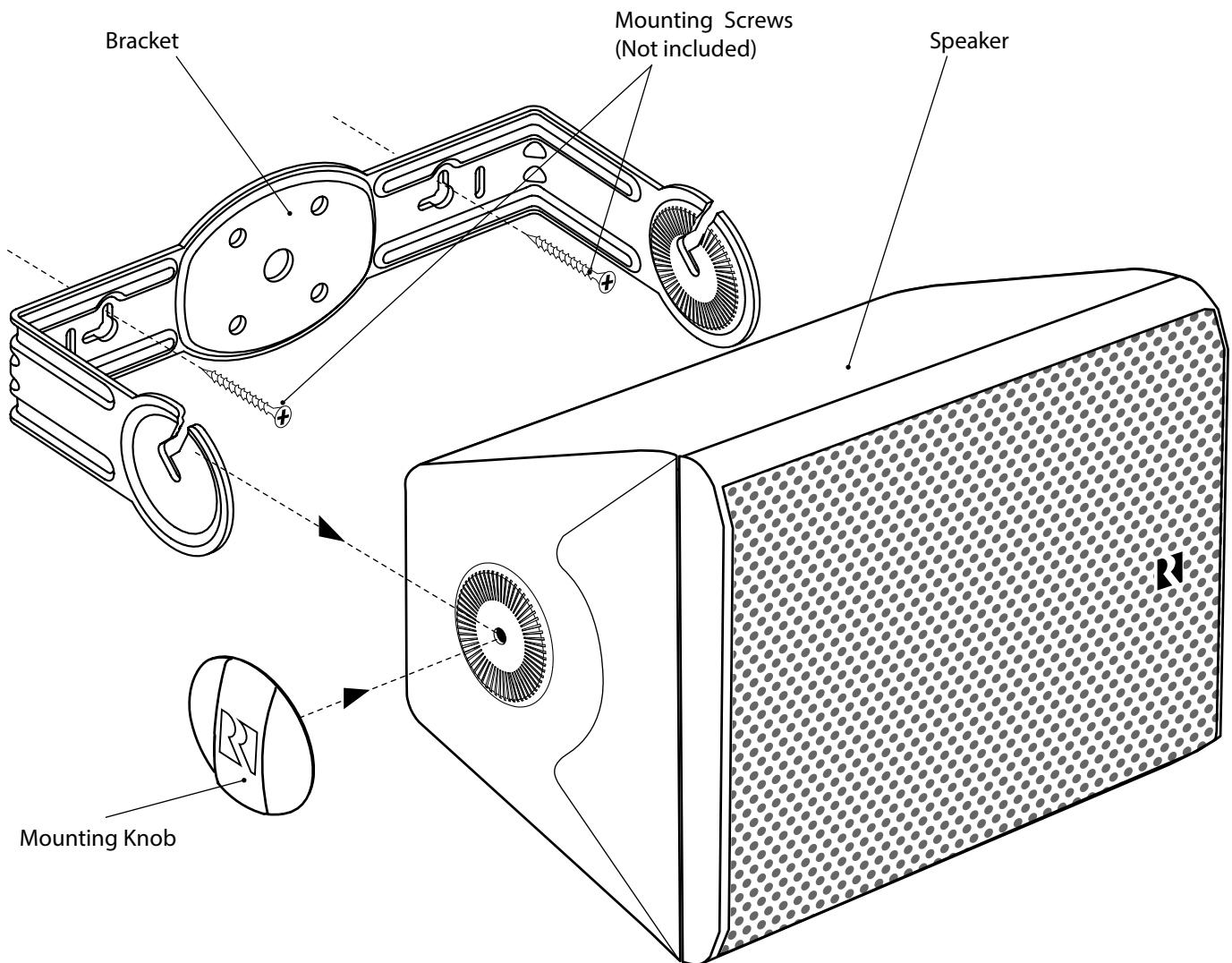

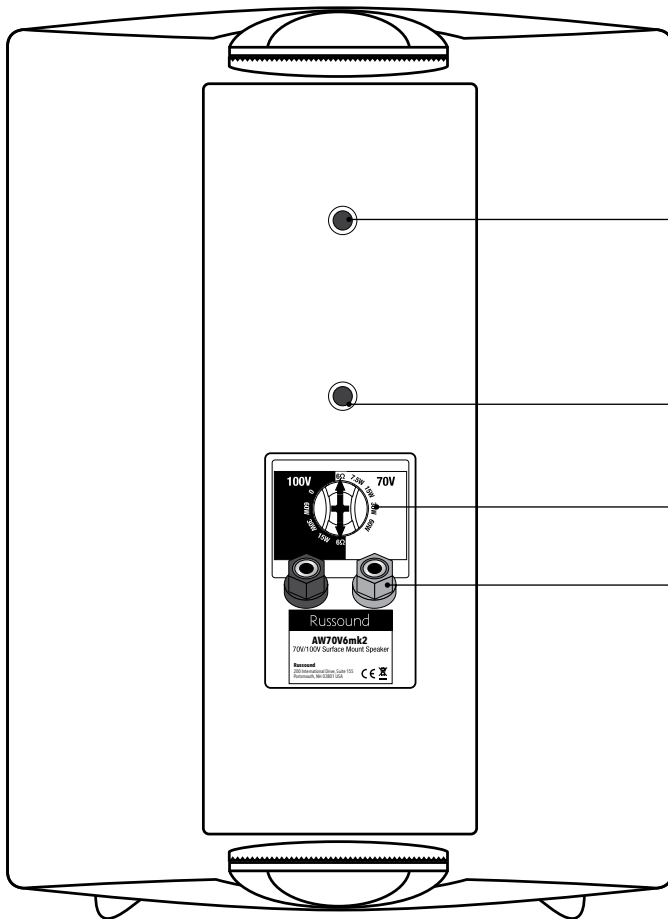

1/4"- 20 Brass Inserts - fits many aftermarket mounting systems if desired. Follow directions included with the aftermarket product.

Tap Setting Knob - for easy adjustment of the tap settings with options for:
7.5W, 15W, 30W, 60W (70V)
15W, 30W, 60W (100V)
6Ω Bypass

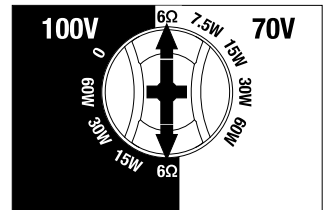

Binding Posts - to secure speaker wire, up to 12 gauge.

WIRING INFO - 70V/100V OPERATION

Speaker cable

Wiring speakers for 70V/100V systems is simple and easy. A single run of 2-conductor, stranded wire is run to every speaker location leaving a small loop (2-3 feet is usually more than sufficient depending on the speakers and their mounting type) at each speaker location. You can place additional loops for future expansion or for making speaker location changes if needed.

Note: This is very different from typical low-impedance wiring used for residential audio installations where a dedicated run of wire goes from each speaker back to the amplifier/receiver. 70V/100V wiring uses much less wire and the wire used can be a much higher gauge (thinner wire) even though it is used in a longer run.

Here is a chart showing some of the differences possible among wire lengths for both low impedance (4Ω-8Ω) and high impedance (70V/100V) systems:

Speaker Cable Length for Various Gauges at Low and High Impedance									
AWG	Power Loss in Cable (% Loss & dB Loss)								
	4 Ohm Speakers			8 Ohm Speakers			70V Speakers		
	11%	21%	50%	11%	21%	50%	11%	21%	50%
	0.5 dB	1 dB	3 dB	0.5 dB	1 dB	3 dB	0.5 dB	1 dB	3 dB
6	277'	571'	1930'	554'	1141'	3859'	2.6mi	5.3mi	18mi
	84m	174m	588m	169m	348m	1.2km	4.14km	8.5km	29km
8	174'	359'	1214'	349'	718'	2428'	1.6 mi	3.4 mi	11.3 mi
	53m	109m	370m	106m	219m	740m	2.6km	5.5km	18.1km
10	110'	226'	764'	219'	452'	1528'	1mile	2mi	7mi
	33.5m	69m	233m	67m	138m	466m	1.6km	3.4km	11.4km
12	69'	142'	480'	138'	284'	959'	3376'	1.3 mi	4.5mi
	21m	43m	146m	42m	87m	292m	1km	2.1km	7.2km
14	43'	89'	302'	87'	179'	604'	2127'	4380'	2.8mi
	13m	27m	92m	27m	55m	184m	648m	1.3km	4.5km
16	27'	55'	185'	53'	110'	371'	1305'	2687'	1.7mi
	8m	17m	56m	16m	38m	113m	398m	819m	2.8km
18	17'	35'	117'	34'	69'	234'	823'	1694'	1mi
	5m	11m	36m	10m	21m	71m	251m	516m	1.75km
20	11'	22'	74'	21'	44'	147'	518'	1068'	3610'
	3m	7m	23m	6m	13m	45m	158m	331m	1.1km
22	7'	13'	46'	13'	27'	91'	321'	661'	2234'
	2m	4m	14m	4m	8m	28m	98m	201m	681m
24	4'	9'	29'	8'	17'	57'	202'	417'	1409'
	1m	3m	9m	2m	5m	17m	62m	127m	429m

Note: Unlike traditional residential audio, 70V/100V systems are typically run in mono sound so that only a single two-conductor wire run is necessary for the speakers. If you want to use multiple wire runs for zoning speakers or other purposes, each 2-conductor wire needs to be independently run back to its own amplifier or amplifier terminals if using a multi-channel amplifier.

1. At each speaker location, cut the loop of wire at the speaker location
2. Strip 1 to 2 inches (2.5 to 5 cm) off the end of the cable jacket. Then strip ½-inch (1.3 cm) of insulation off each wire.
3. Twist the wire strands together so there are no strands separated from the bundle.
4. Connect the wires to the speaker terminals, being sure to

observe proper polarity. For standard speaker cable with red and black wires, connect both red wires (the red wire coming from the 70V/100V connection on the amplifier or the previous speaker if there was one AND the red wire going to the next speaker if there is an additional speaker) to the red positive (+) terminal and both black wires (the black wire coming from the COM connection of the 70V/100V amplifier or the previous speaker if there was one AND the black wire going to the next speaker if there is an additional speaker) to the black negative (-) terminal.

Note: Some speaker cables may have other ways of designating polarity. Cable with a clear jacket has a copper-colored wire for positive and a silver-colored wire for negative. In a cable with white and black wires, the white is positive (70V or 100V) and the black is negative (COM). Cable with both wires the same

WIRING INFO - 70V/100V OPERATION

color may have grooves, ribs, or stripes on the positive wire to identify it.

5. Check to make sure there are no stray strands of wire outside the terminals. If there are, remove the wire, twist the strands

together, and reconnect the wire to the terminal.

6. At the final loudspeaker, the only wires connected will be the ones coming from the previous loudspeaker (or from the amplifier if there is only one speaker in the system).

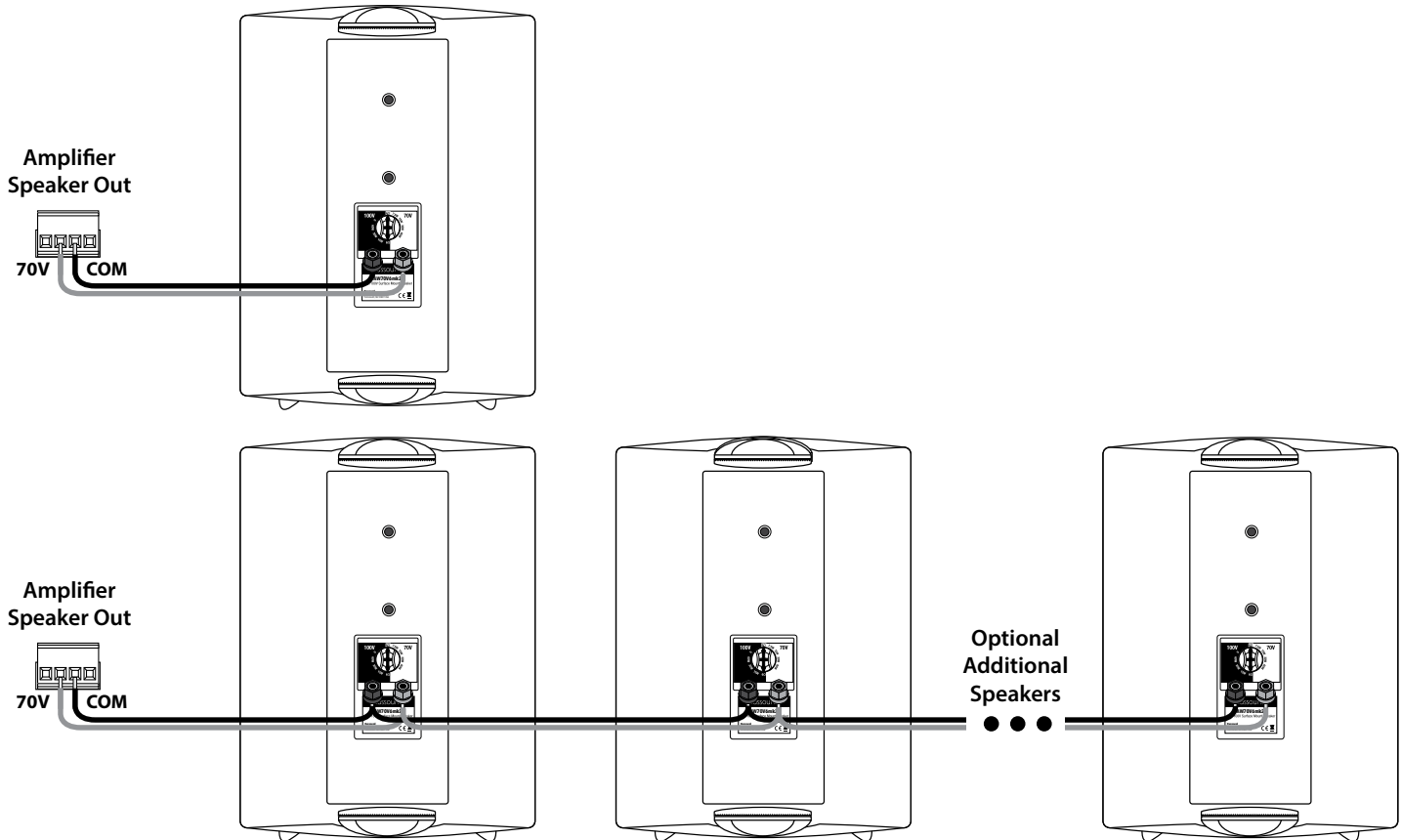

Adjust the Tap Settings

The AW70V6mk2 speakers have the following tap settings available:

70V: 7.5W, 15W, 30W, 60W

100V: 15W, 30W, 60W

6 Ω (bypasses the internal transformer)

The tap settings will affect the overall volume of the loudspeaker in the system. When designing a 70V/100V system, care must be taken not to exceed the power rating of the amplifier or dangerous clipping may occur. Clipping is the most common cause of damage to loudspeakers and should be avoided at all times. The standard rule is to design a system that leaves 20% of the amplifier's rated power as a reserve. For example, with a 300-watt amplifier, speakers should never be set with taps that total higher than 240-watts. The amplifiers total load is determined by adding the wattage of each speaker. When thicker wire or exceptionally long wire runs are used, there is an additional component of current loss due to the cable that can become significant and must be considered in the calculation. For our example with a 300-watt amplifier, here are the approximate number of speakers that could be

used if each speaker used the following tap settings:

Example: 300-Watt Amplifier (saving 20% for overhead, means 240 usable watts maximum)

Tap Settings and maximum number of speakers (depending on wire gauge and length)

7.5W: Max of 28-32 speakers

15W: Max of 14-16 speakers

30W: Max of 7-8 speakers

60W: Max of 3-4 speakers

For a 70V/100V system, most installations are designed to blanket an area using more loudspeakers at a lower tap setting rather than using fewer speakers at a higher tap settings. This is done to avoid hot spots where very loud sound is heard in certain areas and less in others. It is much more common for 70V speakers to be set at their lowest tap setting than at their highest, but each installation may require adjustments due to the application or environment.

You can adjust the tap setting at any time by turning the tap setting knob to the new position, but make sure not to exceed the amplifier's total available wattage when doing so.

WIRING INFO - 6 OHM OPERATION

Speaker cable

The amount of wire needed varies with speaker placement. Label speaker wires with left, right, and location.

Use Russound AW series speaker cable or any reputable brand of 16 to 12 gauge multi-stranded wiring for amplifier- to-speaker connections.

Wire is measured in gauges: the greater the number, the smaller the wire. The gauge of wire needed is determined by the distance between the amplifier/receiver and the speakers. The longer the run, the heavier the gauge needed. Use the following chart as a guide:

Length	Minimum Gauge
0' to 100'	16
50' to 150'	14
100' to 200'	12

The standard colors on the terminals are red Positive (+) and black Negative (-). If the wire has transparent insulation, one conductor will be copper-colored (+) and the other silver-colored (-). If the wire has an opaque insulation, the conductors are differentiated by a series of ribs or grooves, a stripe, or dotted line on one conductor. Use and mark these as the Positive (+) conductor.

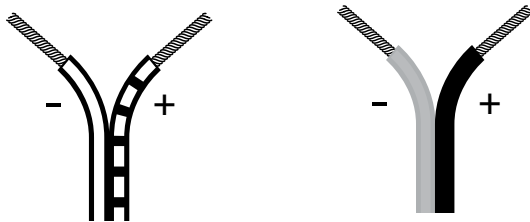

Typical usage of speaker wire conductors

Tap Setting Knob

When using the AW70V6mk2 speakers with a low impedance system (such as with a 4Ω or 8Ω amplifier or receiver), make sure that the tap setting switch is set to the 6Ω position. This is the only appropriate setting when using the AW70V6mk2 speakers with a low impedance amplifier.

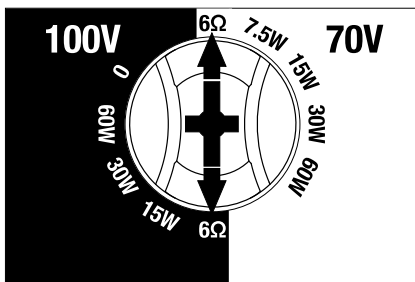

Prewiring

Run a separate 2-conductor stranded copper speaker cable of at least 16 AWG (1.5 mm) from the amplifier to each speaker. Be sure to use cable with the appropriate fire resistance rating for the application.

When running a speaker cable parallel to an AC power cable, keep them at least 12 inches (30 cm) apart to minimize electromagnetic interference. If the speaker cables must cross AC wiring, cross them at right angles.

Leave about 2 feet (0.6 m) of cable at each end for connecting to the speakers and amplifier. Label the cables so you will know which cable connects to each keypad or amplifier output channel.

- Avoid running speaker wires close to house electrical wiring for any distance. If you have to run them parallel, leave two feet between the wiring. Speaker wires should cross AC lines at a 90° angle.
- The entire path between speakers and amplifier should be clear and unobstructed. Confirm the placement for the wall port close to the intended location of the amplifier or receiver.
- Label speaker wires at each end with left and right and location.

Impedance matching for amplifiers and speakers

If you intend to use more than one pair of speakers at a time it's important to consider both the impedance of the speakers and the capabilities of the amplifier or receiver. Not all amplifiers or receivers can safely operate two sets of speakers at once.

Connecting the speaker

1. Strip 1 to 2 inches (2.5 to 5 cm) off the end of the cable jacket. Then strip ½ inch (1.3 cm) of insulation off each wire.
2. Twist the wire strands together so there are no strands separated from the bundle.
3. Connect the wires to the speaker terminals, being sure to observe proper polarity. For standard speaker cable with red and black wires, connect the red wire to the red positive (+) terminal and the black wire to the black negative (-) terminal.

Note: Some speaker cables may have other ways of designating polarity. Cable with a clear jacket has a copper-colored wire for positive and a silver-colored wire for negative. In a cable with white and black wires, the white is positive and the black is negative. Cable with both wires the same color may have grooves, ribs, or stripes on the positive wire.

4. Check to make sure there are no stray strands of wire outside the terminals. If there are, remove the wire, twist the strands together, and reconnect the wire to the terminal.

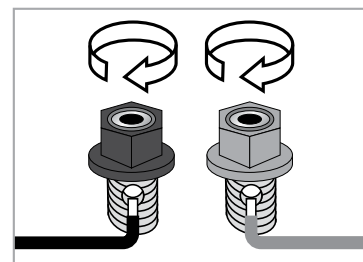

INSTALLING THE BRACKET ON WALL SURFACE

Installing the mounting bracket

The speaker can be installed horizontally or vertically. For a horizontal installation, install the mounting bracket with its end "C" slots at the top. Also, when installing the speaker outdoors in the horizontal position, locate the mounting bracket high enough so the front of the speaker will point down toward the listening area.

Note: The bracket must be securely attached to the mounting surface. For an exterior plywood wall with siding, use rust-resistant screws long enough to penetrate the siding and plywood. For a standard interior hollow wall, we recommend screwing the bracket to the wall studs whenever possible. If the speaker must be mounted between studs, use a minimum of two hollow-wall anchors to secure the bracket. For a masonry wall, use suitable anchors.

Installation on wood

1. Using the mounting bracket as a template, mark the locations of the mounting screws.
2. Drill pilot holes for the screws.
3. For an exterior wall, apply a ring of caulk or sealant around each hole.
4. Screw the bracket to the wall or other surface.

Installation on a hollow wall

1. Once you have determined roughly where to mount the speakers, use a stud finder to locate the wall studs and mark their location.
2. Using the bracket as a template, mark the mounting screw locations.
3. If you are attaching the bracket to studs, use a small drill to make pilot holes for the mounting screws. If you are using hollow-wall anchors, use a drill of the size recommended by the anchor manufacturer.
4. Screw the mounting bracket to the wall studs using suitable screws, or secure the wall anchors in the wall and attach the bracket to them.

Installation on masonry

1. Using the mounting bracket as a template, mark the locations of the mounting screws.
2. Use a masonry drill to make pilot holes for the anchors.
3. Insert the suitable masonry anchors into the pilot holes and attach the mounting bracket with screws.

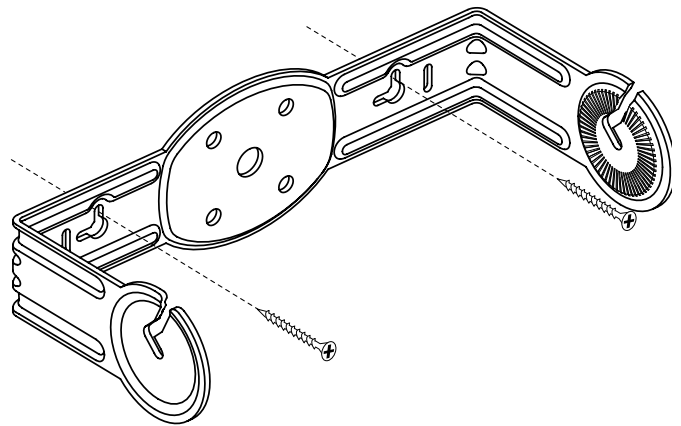

Mounting bracket horizontal position

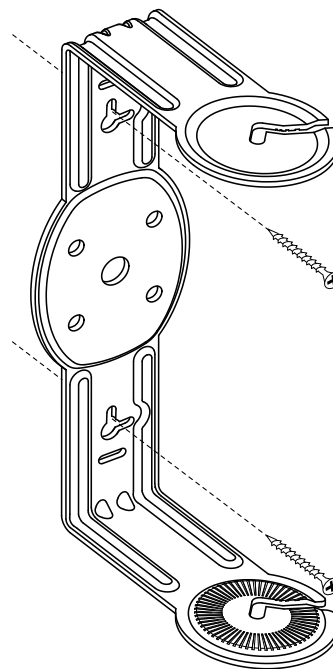

Mounting bracket vertical position

INSTALLING THE BRACKET ON POLE

Installing the mounting bracket on a pole

The speaker can be installed horizontally or vertically on a pole with up to 1" (2.54 cm) inner diameter with two standard 5/16 x 1-3/8 x 1/2" U-bolts with 5/16-18" threads. For a horizontal installation, install the mounting bracket with its end "C" slots at the top. Also, when installing the speaker outdoors in the horizontal position, locate the mounting bracket high enough so the front of the speaker will point down toward the listening area.

Installation on pole

1. Pass two standard U-bolts behind the pole and slide bracket over ends.
2. Attach bracket with lock washers and bolts, and tighten.

Installation on in-ground pole

The speaker can be mounted on an in-ground pole with buried cable. First, consult your local utility companies to learn of existing buried cables, pipes or lines. Be aware of any local building code requirements that may be applicable.

1. Drive a 1" (2.54 cm) pipe into the ground at the pre-qualified location. Determine the length and location for the cable trench and dig below the frost line. Use either direct buried speaker cable or cable run through conduit.
2. Pass two standard U-bolts behind the pole and slide bracket over ends.
3. Attach bracket with lock washers and bolts, and tighten.
4. Leave about 2 feet of cable at the speaker end for connections and adjustments.

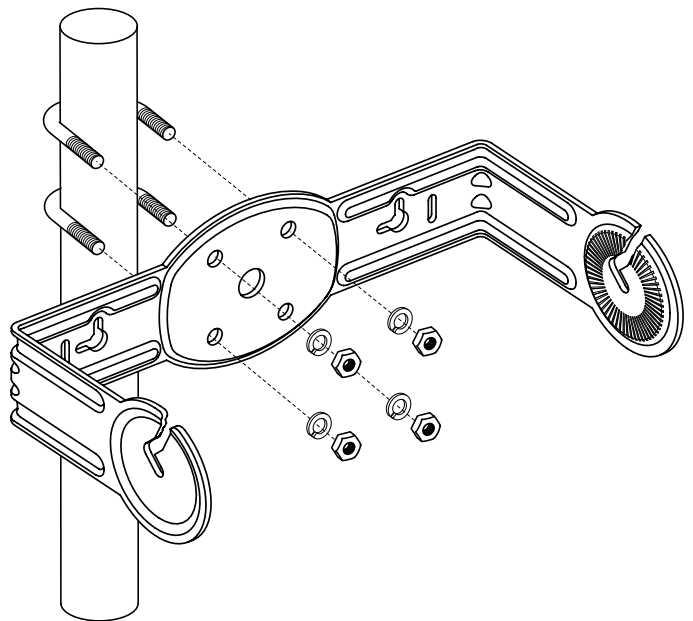

Mounting bracket horizontal position

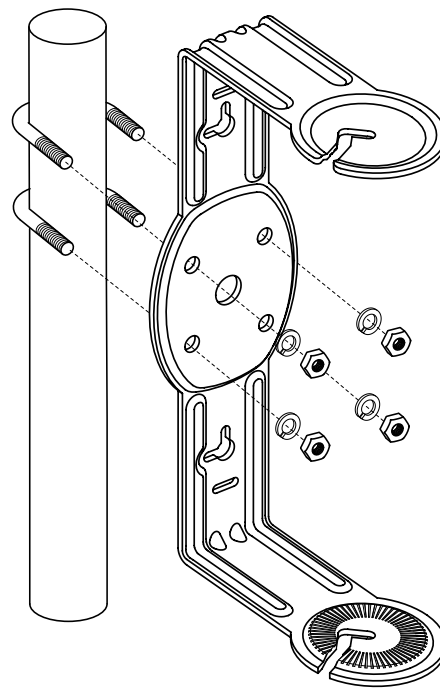

Mounting bracket vertical position

Attaching the speaker to the bracket

1. Attach the knob loosely, allowing about a 1/3" (8-10mm) gap between the knob and the speaker.
2. Insert the speaker onto the mounting bracket.
3. Tighten the knobs on both ends.

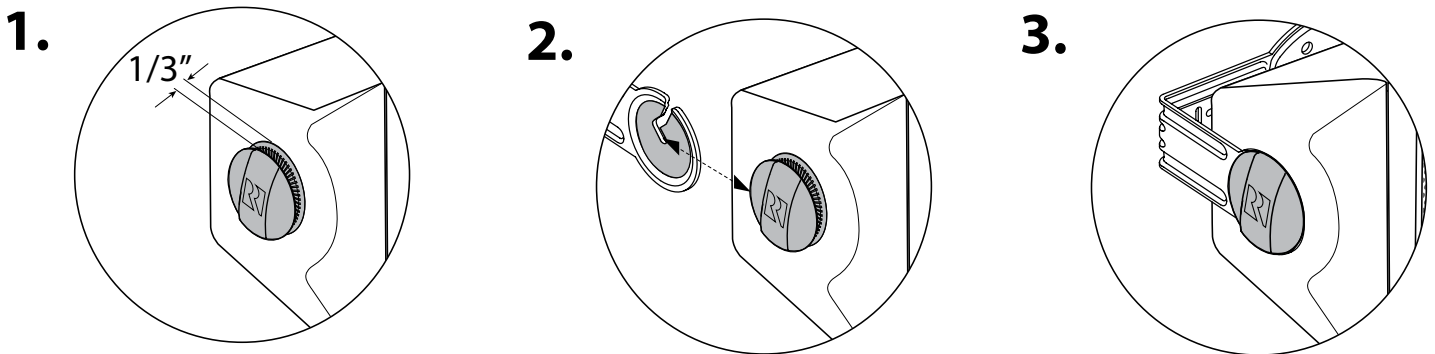

Russound Logo – The Russound logo on the aluminum speaker grille is rotatable for installations where the speaker is installed horizontally instead of vertically. Simply lift the logo slightly until it can rotate, and then rotate it to the desired orientation. Release the logo when finished and it will spring back into position.

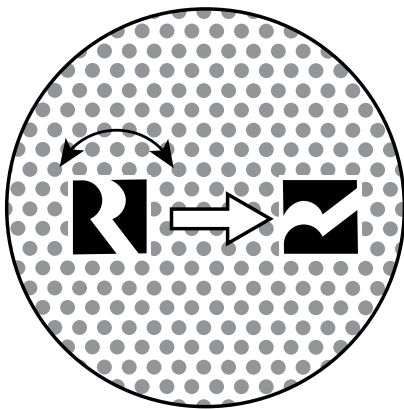

Description: 70V/100V Surface Mount Indoor/
Outdoor Speaker Pair

Woofers: 6.5" (16.51cm) Injection-Molded
Polypropylene

Tweeter: 1" (2.54cm) Titanium Dome

Dimensions: 11.875"H x 8.5"W x 7.5"D
(30 x 21.6 x 19 cm)

Terminals: 12 gauge screwdown terminal

Grille: Powder Coated Aluminum

Bracket: Aluminum

Recommended Power: 10 - 100 watts RMS for low
impedance systems

Tap Settings: 7.5W, 15W, 30W, 60W (70V)
15W, 30W, 60W (100V)
6Ω Bypass

Sensitivity: 87 dB

Frequency Response: (+/- 3dB): 55Hz-20kHz

Unit Weight: 9 lbs. (4 kg))

Speaker care

These sealed construction speakers are made of durable materials that need very little care. Occasionally wipe them with a soft, damp cloth. Do not use any harsh detergents, chemical solvents, or abrasive materials on your speakers, and do not spray water or other liquids into the grilles.

The Russound AW70V6mk2 Speaker is guaranteed against all defects in materials and workmanship for two (2) years from the date of purchase. During this period, Russound will replace any defective parts and correct any defect in workmanship without charge for either parts or labor.

For this warranty to apply, the unit must be installed and used according to its written instructions. If service is necessary, it must be performed by Russound. The unit must be returned to Russound at the owner's expense and with prior written permission. Accidental damage and shipping damage are not considered defects, nor is damage resulting from abuse or from servicing by an agency or person not specifically authorized in writing by Russound.

This Warranty does not cover:

- Damage caused by abuse, accident, misuse, negligence, or improper installation or operation
- Power surges and lightning strikes
- Normal wear and maintenance
- Products that have been altered or modified
- Any product whose identifying number, decal, serial number, etc. has been altered, defaced or removed.

Russound sells products only through authorized Dealers and Distributors to ensure that customers obtain proper support and service. Any Russound product purchased from an unauthorized dealer or other source, including retailers, mail order sellers and online sellers will not be honored or serviced under existing Russound warranty policy. Any sale of products by an unauthorized source or other manner not authorized by Russound shall void the warranty on the applicable product.

Damage to or destruction of components due to application of excessive power voids the warranty on those parts. In these cases, repairs will be made on the basis of the retail value of the parts and labor. To return for repairs, the unit must be shipped to Russound at the owner's expense, along with a note explaining the nature of service required. Be sure to pack the unit in a corrugated container with at least three (3) inches of resilient material to protect the unit from damage in transit.

Before returning a unit for repair, call Russound at (603) 659-5170 for a Return Authorization number. Write this number on the shipping label and ship to:

Russound

Attn: RA# (Insert your RA number here)

1955 Wehrle Dr

Williamsville NY 14221

Due to continual efforts to improve product quality as new technology and techniques become available, Russound/FMP, Inc. reserves the right to revise system specifications without notice.

a sound relationship

Russound

AW70V6mk2

70V Surface Mount Indoor/Outdoor Speakers

Installation Manual

©2023 Russound/FMP, Inc. All rights reserved. All trademarks are property of their respective owners. Specifications are subject to change without notice. Russound is not responsible for typographical errors or omissions.

Russound, Inc.
200 International Drive, Suite 155
Portsmouth, NH 03801 USA
tel 603.659.5170
email: tech@russound.com www.russound.com

04.2023 Rev.3